

SINCE 1908  
**wessels**  
 company

**SUBMITTAL**

**DM-GMP-SERIES**

DRUM MOUNT GLYCOL MAKE-UP PACKAGE

Models: DM-GMP-13000 thru DM-GMP-15000

Submittal Sheet No. I-1107A

Date: 1/24

Job Name _____	Submitted By _____	Date _____
Location _____	Approved By _____	Date _____
_____	Order No. _____	Date _____
Engineer _____	Notes _____	
Contractor _____	_____	
Sales Rep. _____	_____	

**Description**

The single DM-GMP unit is designed to automatically supply a pressurized solution, such as glycol and water, to a closed loop heating, chilled water, snowmelt, radiant heating, sprinkler, or process control system to ensure minimum system pressure requirements are met. These systems are equipped with HOA controls, an adjustable pressure reducing valve (PRV), pressure gauge, and a low level alarm that cuts power to the pump and actuates an audible and visual alarm when solution levels are too low.

**Performance Limitations**

Maximum Temperature: 160°F  
 Factory Discharge Pressure Setting: 12 PSIG  
 Maximum Discharge Pressure: 70 PSIG\*

\*Higher Discharge pressures available.

**Available Options**

- High level alarm

Model Number	Part Number	Tagging Information	Quantity
DM-GMP-13000	07101050		
DM-GMP-15000	07102050		

**Typical Specification**

Furnish and install, as indicated on the plans and specifications, a prefabricated, automatic and autonomous make-up package capable of producing \_\_\_\_\_ GPM at \_\_\_\_\_ psig to each glycol system. The package shall consist of a sturdy steel frame with removable lid, and a 110V, 60Hz powered autonomous pumping assembly designed to maintain a specific fill pressure in the glycol system. The make-up package must feature a protective low water cut-off alarm, HOA controls, \_\_\_\_\_ HP (1/3 or 1/2) motor with a brass rotary vane pump, magnetic starter, pressure tank with pressure control, pressure reducing valve, pressure gauge, and a system isolation valve. A 110V signal shall be available for a remote alarm.

Each glycol make-up package shall be model DM-GMP - \_\_\_\_\_ as manufactured by Wessels Company or approved equal.

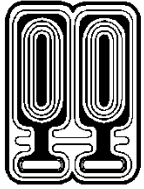

SINCE 1908  
**wessels**  
 company

SUBMITTAL

**DM-GMP-SERIES**

DRUM MOUNT GLYCOL MAKE-UP PACKAGE

Models: DM-GMP-13000 thru DM-GMP-15000

Submittal Sheet No. I-1107A

Date: 1/24

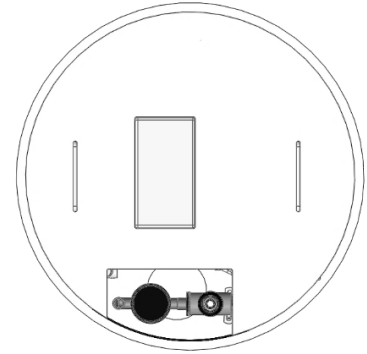
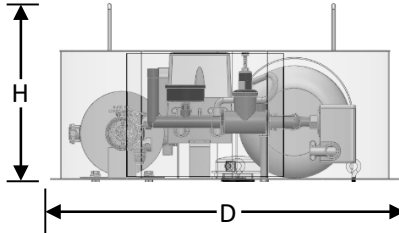
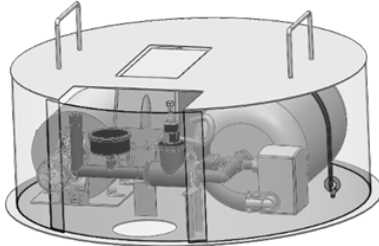

DM-GMP-13000 thru DM-GMP-15000

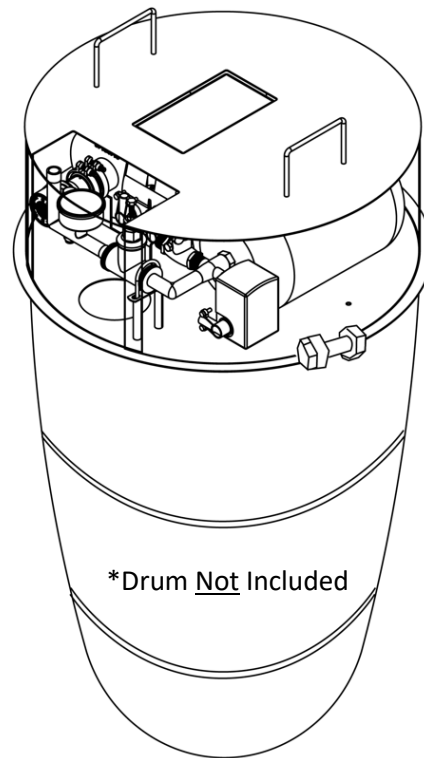

**Dimensions & Weights**

Model Number	Dimensions In Inches		HP	Pressure Range (psi)	Make-Up Capacity (gpm @ psi)	Approx Shipping Weight (lbs)
	H	D				
DM-GMP-13000	10 1/2	22	1/3	10-70	1.8 @ 70	56
DM-GMP-15000			1/2	10-90		95