

SINCE 1908
wessels
 company

SUBMITTAL

SPA-R-SERIES
 SEVERE SERVICE AIR SEPARATOR

Models: SPA-R-2 TO SPA-R-24
 Submittal Sheet No. D-1007A Rev. 1 3/20/2024

Job Name _____	Submitted By _____	Date _____
Location _____	Approved By _____	Date _____
_____	Order No. _____	Date _____
Engineer _____	Notes _____	_____
Contractor _____	_____	_____
Sales Rep. _____	_____	_____

Description

Wessels SPA-R Vortex type air separators with non-replaceable strainer are built in accordance with ASME boiler and pressure vessel code to eliminate air quickly and efficiently from open and closed loop heating/cooling systems. Fluid enters and exits tangentially, which creates a low velocity vortex in the center of the unit. Centrifugal force creates an area of low pressure that causes air to come out of solution and travel to the top where it can be released or captured. The strainer breaks surface tension and removes solids from suspension where they can be eliminated from a blowdown valve. Bubble-free fluid exits near the bottom of the unit, protecting systems against the noise, corrosion, and damage commonly caused by entrained air.

Construction:

Shell: Carbon Steel
 Heads: Carbon Steel

Design Parameters:

Maximum Design Pressure: 125 PSIG**
 Temperature Range: 0°F to 450°F

**200 & 250 PSIG available

MODEL NUMBER	PART NUMBER	MAX FLOW (GPM)	TAGGING INFORMATION	QUANTITY
SPA-R-2N	72410001	56		
SPA-R-2.5N	72410002	90		
SPA-R-3	72410005	190		
SPA-R-4	72410009	300		
SPA-R-5	72410013	500		
SPA-R-6	72410017	700		
SPA-R-8	72410021	1300		
SPA-R-10	72410025	2000		
SPA-R-12	72410029	2750		
SPA-R-14	72410033	3840		
SPA-R-16	72410037	5015		
SPA-R-18	72410041	5200		
SPA-R-20	72410045	6300		
SPA-R-22	72410049	7400		
SPA-R-24	72410053	8500		

Typical Specification

Furnish and install, as shown on plans, a centrifugal vortex type AIR SEPARATOR model SPA-_____-R sized for _____ GPM, with _____" (NPT/Flanged) tangential connections, as manufactured by Wessels Company. The unit shall have an internal type 304 perforated stainless-steel tube with open area designed to direct accumulated air to an air vent or compression tank via an NPT connection at top of separator. A blowdown connection shall be provided to facilitate routine flushing of collected sediment in the unit. Separator shell diameter to be three times the nominal inlet/outlet pipe diameter, to create proper centrifugal separation over the range of the separator design flow. The tank must be constructed in accordance with most recent edition of Section VIII Division 1 of the ASME Boiler and Pressure Vessel Code, and shall be constructed and stamped for 125 PSIG working pressure at 0°F to 450°F.



SINCE 1908
wessels
 company

101 Tank Street Greenwood, IN 46143
 P: 317-888-9800 F: 317-865-7411
 www.westank.com

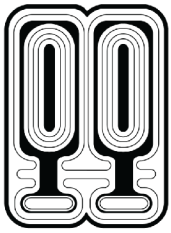

SINCE 1908
wessels
 company

SUBMITTAL

SPA-R-SERIES
 SEVERE SERVICE AIR SEPARATOR

Models: SPA-R-2 TO SPA-R-24
 Submittal Sheet No. D-1007A Rev. 1 3/20/2024

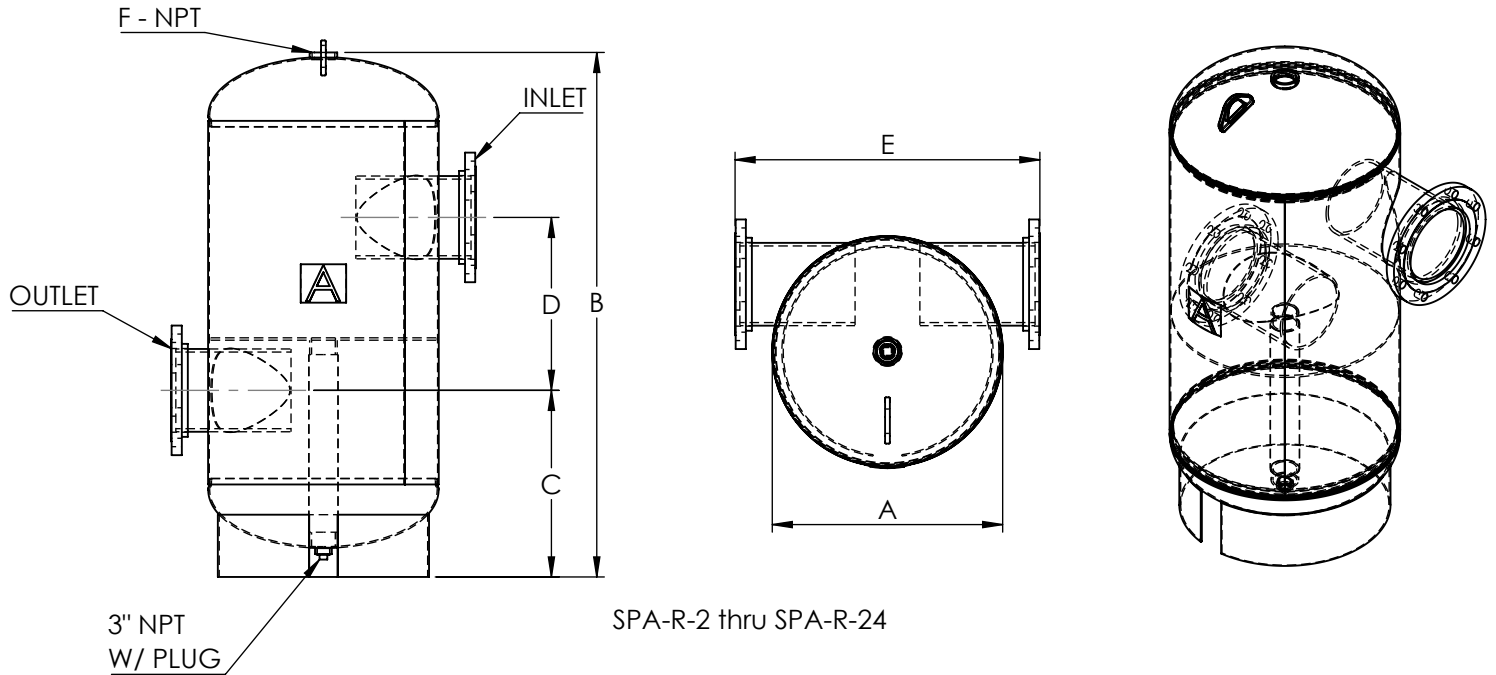

Dimensions & Weights:

Model Number	Dimensions in Inches							Approx. Shipping Weight (lbs)
	Connection Size	A	B	C	D	E	F	
SPA-R-2N	2 NPT	12	24 11/16	9 5/16	8 1/2	16 5/8	1 1/4	43
SPA-R-2.5N	2.5 NPT							59
SPA-R-3	3	10 3/4	26 7/8	10 13/16	8	20 1/2		115
SPA-R-4	4	12	31 9/16	12 1/16	10	22 3/4	1 1/2	155
SPA-R-5	5	16	37	14 1/16	12	23 3/4		205
SPA-R-6	6	18	44 1/16	16 13/16	14	25 3/4		280
SPA-R-8	8	24	54	19 7/16	18	31 3/4	2	420
SPA-R-10	10	30	64 11/16	22 5/8	22	37 3/4		800
SPA-R-12	12	36	75 3/8	25 3/4	27	46 3/4		1110
SPA-R-14	14	42	92 3/8	35	31 1/2	54 1/2		1780
SPA-R-16	16	48	104 3/8	38 1/8	36	62 1/2		2425
SPA-R-18	18	54	123 1/4	44 3/4	40 1/2	70 1/4		3410
SPA-R-20	20	60	135 1/2	48 5/8	45	78		5310
SPA-R-22	22	66	148 1/2	52 5/8	49 5/8	85 7/8		6400
SPA-R-24	24	72	159 1/2	56 1/8	54	93 1/2	7500	

Notes:

- Mounting Clips Available Upon Request
- Flanged connection is standard unless otherwise specified



SINCE 1908
wessels
 company

101 Tank Street Greenwood, IN 46143
 P: 317-888-9800 F: 317-865-7411
 www.westank.com